

# RainSoft®

*Environmental Products for the Home ...since 1953*

## **TC CONDITIONER SERIES WATER TREATMENT SYSTEM**

# Owner's Manual



This product is manufactured in an ISO 9001:2000 certified facility.



The TC series is tested and certified by the WQA to NSF/ANSI 44 for the specific performance claims as verified and substantiated by test data. See the performance data sheet for specific reduction claims.

# Table of Contents

Information on Water Treatment Systems .....	3
Application Limitations .....	3
Operational Specifications .....	4-6
Salt Requirements.....	7
Resin Cleaners.....	7
Maintenance Requirements.....	7
Product Certification Information.....	7
Installation Instructions .....	8-11
System Start Up.....	12
Customer Settings.....	13
Installers Section.....	14-15
How to Calculate the Regeneration Schedule .....	15-16
Troubleshooting Guide .....	16
Warranty Information .....	17
Exploded Views and Parts Lists.....	18-21
Place for Notes .....	22-23

**Congratulations** on your purchase of a RainSoft water treatment system.

This Owner's Manual is designed to assist with the operation, maintenance, and installation of your water treatment system. It is our sincere hope that this manual is clear, concise, and helpful to you as a new owner.

**Questions?** If you have any questions regarding the installation, operation, or servicing of this system, please contact your local RainSoft Dealer. Your local RainSoft Dealer is familiar with your particular water conditions, and is able to address your concerns promptly and efficiently.

## Information on Water Treatment Systems

There are many misconceptions that have been developed about water treatment systems. The most common topic of confusion is the amount of sodium (Na), not table salt (NaCl), that is added to the water from a water conditioner. In reality, ion exchange does replace the hardness ions in your water with sodium ions, but the common misconception is the amount used.

For every 1 grain of hardness, the exchange process will deliver approximately 8 milligrams of sodium per 1 liter of water. The amount of sodium present in a standard 8 ounce glass of treated water, that was 10 grains hard prior to treatment, would be around 19 milligrams of sodium. This is an insignificant amount of sodium considering a typical slice of white bread has about 140 milligrams.

Another common misconception that needs mentioning is the amount of salt used by the conditioner to regenerate the system. In the past, water conditioners used more salt to regenerate, but that was due to old technology and standards. Water conditioners do use salt for regeneration, but the amount of salt varies by water consumption and hardness levels. Fortunately, today's technology allows us to dispense just the right amount of salt for maximum efficiency, based on your individual water consumption needs.

## Application Limitations

- On hardness levels of 60 grains and higher, the system may not achieve a hardness of less than 1 grain; due to high Total Dissolved Solids, some bleed through is possible. Bleed through can also be caused by sodium levels higher than 1000 parts per million. In either case, your system can be programmed to minimize these effects. See your RainSoft Dealer for details.
- Chlorine or Chloramine levels on municipality treated water should not exceed 4 parts per million.\* When Chlorine or Chloramine levels are 4 parts per million\* or greater, it can have adverse effects on your system. In applications where high levels are a concern, pre-filtration is necessary to reduce the Chlorine or Chloramine to an acceptable level. See your RainSoft Dealer for details.
- When this system is installed on water with Ferrous iron, also known as clear water iron, the maximum range of removal is based on local water conditions. The range is generally 2 to 10 parts per million. Your equipment may require special programming, along with an additive to the brine tank, to maximize the equipment's ability to remove iron. See your RainSoft Dealer for details.

**Helpful Tip:** Another common misconception of water treatment systems is the idea that soft water will produce clear ice cubes. Cloudy or white, hazy ice cubes are caused by air that is slowly being released from the water during the freezing process, which has nothing to do with the performance of your system.

**! Important Note:** This system may be installed on well water or municipality treated water supplies.

**! Important Note:** Most municipality treated water supplies contain Chlorine as a disinfectant. Many municipalities also inject ammonia into the water supply, creating Chloramine.

\* Maximum disinfectant level of Chlorine or Chloramine recommended from the EPA.

**! Important Note:** Iron fouled resin is not eligible for warranty replacement.

The amount of iron reduced by your conditioner is based on the incoming pH. Consult your local RainSoft dealer for more details.

# Operational Specifications

## Plumbing

3/4 inch to 1 1/4 inch

## Drain Line

1/2 inch

## Water Pressure

20 psi–120 psi (1.38 bar – 6.89 bar)

## Operating Temperatures

40° F–100° F (4.4° C – 37.8° C)

## Electrical Requirements

A properly grounded alternating current supply (110 VAC 60 Hz or 230 VAC 50 Hz) is required for the operation of this system. Please check the transformer for the correct voltage requirements.

**! Important Note: This system requires the use of the supplied transformer (24 VAC).**

## Bypass Valve

The bypass valve enables you to bypass the system in situations of: emergency leaks in the equipment, service calls and/or outdoor water use.

**! Important Note: The manually operated bypass valve enables the conditioner to be isolated from the water service line for maintenance and service. It also maintains the continuity of the water supply when the conditioner is disconnected.**

## Existing Plumbing Conditions

Plumbing should be free from lime and/or iron buildup. Piping that contains large amounts of lime and/or iron should be replaced. If piping is clogged with iron, a separate iron filter should be installed in-line, before the water conditioner.

## Additional Specifications

- Do not install this system where water is microbiologically unsafe or of unknown quality without adequate disinfection before or after the system.
- This system must be installed in accordance with all applicable state and local laws and regulations.
- The Commonwealth of Massachusetts Plumbing Code 248 CMR shall be adhered to. A licensed plumber shall be used for this installation.
- This system must be installed in an area not affected by extreme heat, cold or the elements. The selected installation area must be adequate for easy service and accessibility.
- This system is designed to treat cold water only. The installation must be on a cold water supply.

## Data Chart for ION-X 2000 V Resin

Model	Tank Size (inches)	Resin* (cu. ft.)	Service Flow (gpm)	Drain Flow (gpm)	psi Drop	High Salting	Medium Salting	Low Salting
TC 50 V	8 x 44	0.5	10.0	1.5	12.0	18,700 @ 7.5 lbs.	16,000 @ 5.0 lbs.	8,900 @ 2.0 lbs.
TC 50 CV	8 x 44	0.5	10.0	1.5	14.0	18,700 @ 7.5 lbs.	16,000 @ 5.0 lbs.	8,900 @ 2.0 lbs.
TC 60SS V	10 x 18	0.6	9.5	2.0	10.0	22,000 @ 9.0 lbs.	18,700 @ 6.0 lbs.	10,500 @ 2.4 lbs.
TC 60SS CV	10 x 18	0.6	9.5	2.0	9.0	22,000 @ 9.0 lbs.	18,700 @ 6.0 lbs.	10,500 @ 2.4 lbs.
TC 60S V	10 x 35	0.6	9.5	2.0	10.0	22,500 @ 9.0 lbs.	19,200 @ 6.0 lbs.	10,700 @ 2.4 lbs.
TC 60S CV	10 x 35	0.6	9.5	2.0	10.0	22,500 @ 9.0 lbs.	19,200 @ 6.0 lbs.	10,700 @ 2.4 lbs.

\* Cation Exchange Media

Higher or lower pressure will affect the efficiency of the system.

## Salt Requirements

Two salt types are recommended for water conditioners:

**Block Salt:** Water conditioner block salt is reasonably priced, low in impurities, and will not cake in the salt container.

**Solar Salt:** Solar salt is reasonably priced and low in impurities.

**! Important Note: Rock salt is not recommended for RainSoft water conditioners. If rock salt is used, the salt container must be cleaned out periodically. DO NOT USE GRANULATED SALT! The use of granulated salt may cause service problems.**

## Resin Cleaners

It is always wise to provide preventative maintenance for your system. If small amounts of iron are present in your water, use a salt containing iron remover or add RainSoft water conditioner cleaner to the salt tank when adding salt. If an excessive amount of iron is present in your water, we recommend the installation of an iron filter before the conditioner. See your RainSoft Dealer for details.

**U Helpful Tip: Resin cleaner will prevent the treatment media from becoming iron fouled.**

**! Important Note: If you use a cleaner containing nitric acid or other strong oxidizing agents, please use caution and follow instructions carefully.**

## Maintenance Requirements

### Cleaning the Regeneration Valve

The regeneration valve body is designed to last a lifetime, but from time to time it may be necessary to clean and lubricate the moving parts. Your water quality and the amount of regenerations necessary will affect this maintenance schedule. Your local RainSoft Dealer is knowledgeable in the different water qualities and will have the necessary parts to complete this service.

**U Helpful Tip: We recommend that this service be performed every three years or earlier if necessary.**

### Testing Your Water

If you are relying on this system for barium and radium reduction, we recommend testing your water periodically (2 times a year) with a hardness test strip (supplied) to ensure that the system is performing properly, and that hardness, barium, and radium are being reduced. Additional hardness test strips are available at no charge from RainSoft. Please call 1-800-860-7638 for your free two year supply.

**! Important Note: The supplied test strip only tests for hardness. A reduction of hardness is also an indication that barium and radium are being reduced.**

In between testing, you can easily monitor the system's performance in the shower or while washing your hands. The feeling of soft water should be present on your skin.

## Product Certification Information

The TC Series is tested and certified by the WQA to NSF/ANSI Standard 44 for the specific performance claims as verified and substantiated by test data. Please refer to the performance data sheets for specific reductions claims.

Water treatment devices sold to retail consumers in California, accompanied by certain health claims, must be certified by the State of California Department of Public Health. The TC Series is not certified in the State of California for the purpose of making health claims.

# Installation Instructions

## 1. Safety Precautions

- To prevent an accident and/or injury, do not hoist the unit over your shoulder. Use a hand truck to transport the unit.
- Do not lay the unit on its side.
- Wear safety glasses and work gloves during installation.

## 2. Test the Raw Water

- Test the raw water for hardness, iron and/or any other element that could affect the performance of the system.

## 3. Check the Water Pressure

- Use a pressure gauge to confirm that the water pressure does not exceed 100 psi. If the water pressure does exceed this limit, install a pressure regulator on the inlet pipe of the unit. The minimum water pressure for a conditioner is 20 psi. 60 psi is the optimum operating pressure.

## 4. Locate a Site for the System

- There are three primary requirements needed for a site: the main water source, a drain and an electrical connection. Locate the system as close to these items as practical. Avoid drain lines over 25 feet long. In most applications, bypass any outside faucets.
- Place the system in the desired location. The location should have a level, smooth, and clean surface.
- If the system is located outdoors, protect the unit from direct sunlight. Direct sunlight can damage the fiberglass and other system components. If necessary, build a box or shed.

## 5. Install the Valve Head

- Remove the cap plug from the tank.
- Lubricate the riser pipe o-ring and tank o-ring with the proper silicone lubricant.
- Attach the supplied upper basket to the bottom of the control valve; twist to lock in place.
- Align the upper basket with the riser pipe and slowly lower the control valve onto the riser pipe, using a twisting motion.
- Align the control valve with the tank. Push down on the control valve and continue to turn it clockwise until the valve o-ring seals against the tank.

## 6. Turn Off the Water and Drain the Plumbing

- Turn off the water at the meter or the pressure tank.
- To drain the plumbing system, open all faucets in the house and flush the toilets. The water will drain out of the lowest faucet or outlet.
- Do not sweat pipes with water in them or while attached to the system; steam will damage the plastic parts in the valve.
- Do not point the soldering torch directly at the mineral tank or control valve. These composite materials will last a lifetime, but cannot withstand the intense heat from a torch.

**! Important Note: For Massachusetts Residents Only: The Commonwealth of Massachusetts Plumbing Code 248 CMR shall be adhered to. A licensed plumber shall be used for this installation.**

**! Helpful Tip: The drain may be a floor drain, a sewer trap, utility sink, vent stack, dry well, etc., depending on local plumbing codes.**

**! Important Note: The system can only be installed outdoors in climates that do not reach freezing levels.**

**! Important Note: Not Applicable for TC-CAB and SS Models.**

**! Important Note: Do not over-tighten the valve to the tank.**

**! Helpful Tip: This procedure will allow air to enter the plumbing system.**

**! Important Note: Applicable for copper plumbing installations.**

- Avoid short connections of pipe between the system and the water heater. If you can't avoid a short connection, move the system to another location. As a last resort, install a heat trap or check valve. If this causes "water hammer", install a water hammer suppressor.

## 7. Bypass the Outside Faucets

- Install plumbing pipes to bypass the outside faucet(s). If the plumbing is not accessible, provide an untreated hose bib on the inlet pipe.

## 8. Install the Pipe Connector (Yoke) to the Bypass Valve

- Once the plumbing is complete, connect the yoke to the bypass valve (see figure 1).

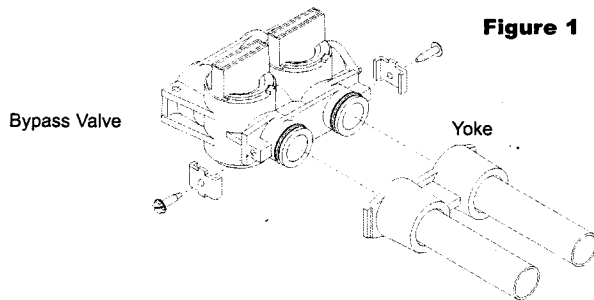

Figure 1

- Support all plumbing connected to the yoke.
- Connect the raw water supply to the inlet pipe connection of the yoke. When looking at the front of the system, the inlet is the pipe connection on the right side of the valve (see figure 2). The arrow molded into valve indicates the direction of flow.
- Connect the treated water pipe to the outlet pipe connection on the yoke. When looking at the front of the system, the outlet is the pipe connection on the left side of the valve (see figure 2). The arrow molded into the valve indicates the direction of flow.
- When installing on metallic plumbing, connect grounding pipe clamp and cables between the inlet and outlet of the tank. (see figure 2)

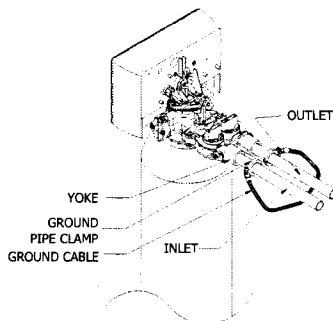

Figure 2

## 9. Set the Bypass Valve to Bypass

- Move the bypass valve handles to the bypass position. The valve handles should be perpendicular to the pipes (see figure 3).

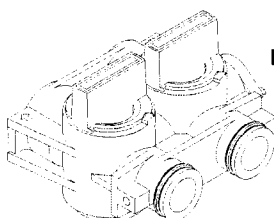

Figure 3

**Important Note: Short connections of pipe may allow hot water to back up into the system. Connections are considered to be short if less than 6 feet in length.**

**Important Note: The bypass valve is not designed to withstand heat from soldering or twisting from the attached threaded connections.**

**Important Note: Too much weight on the plumbing connections will cause a leak.**

**Important Note: Grounding cable to be 1/4" bronze (bare) stranded ground cable of sufficient length to allow pipe joint to flex.**

**Ground conductivity of all piping, equipment, devices, cable and connections must be checked for electrical continuity at the time of installation and periodically thereafter.**

## 10. Install the Drain Line and Air Gap (Air Gap Not Supplied)

- For all drain lines, use at least a 1/2 inch ID line.
- Connect the drain line to the drain outlet on back of the valve, opposite the inlet connection (see figure 4). A fitting is required to

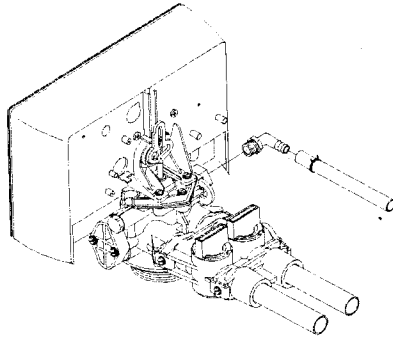

Figure 4

connect the female pipe thread to the drain line.

- Run the drain line to the air gap. The air gap must be installed between the end of the drain line and the drain to prevent possible

**! Important Note: The air gap should be two times the diameter of the drain line or a minimum of two inches. Please check your local plumbing codes to ensure compliance.**

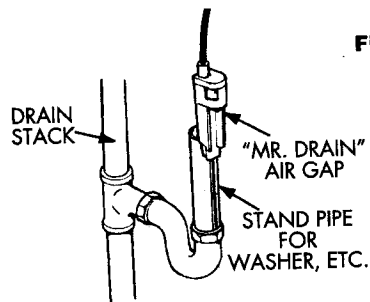

Figure 5

back siphoning (see figure 5).

## 11. Install the Brine Safety Float

- Insert the brine well into the brine tank (see figure 6).
- Attach the brine well to the brine tank with the overflow elbow (see figure 6).

**! Important Note: Not Applicable for TC-CAB Models.**

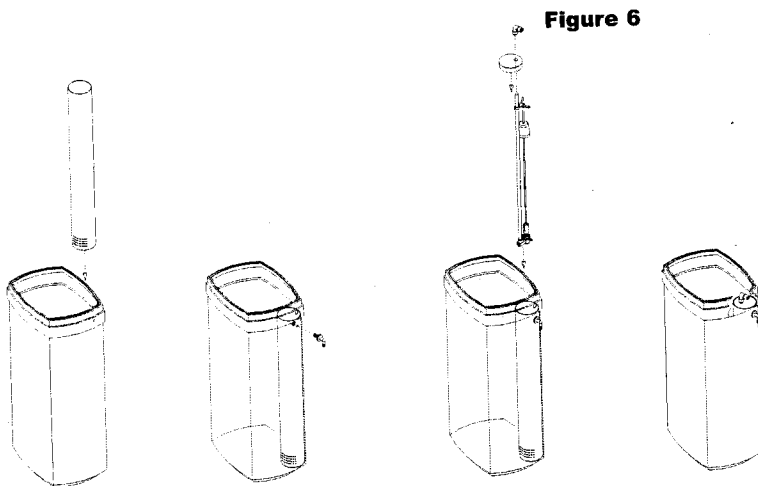

Figure 6

## 12. Install the Brine Line

- Slide the brass compression nut over the end of the brine line, followed by the ferrule and tube support. Attach the brine line to the brass fitting on the right side of the valve (see figure 7).
- Insert a tube support into the other end of the brine line and push the brine line into the brine safety float elbow. Use a locking clip to secure the connection (see figure 7).

## 13. Install the Brine Overflow Line

- Run a 1/2 inch brine overflow line from the overflow elbow on the side of the brink tank to an approved air gap device and suitable floor drain. Use a drain clip to secure the connection (see figure 7).

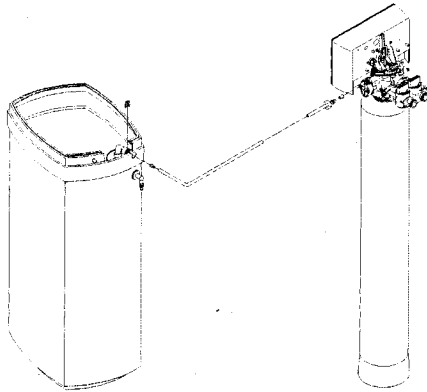

Figure 7

## 14. Attach the Electrical Connection

- Remove the supplied wire from the warranty pack.
- Attach the U shaped connectors (supplied) to the wire with a crimping tool (not supplied).
- Connect the wire to the transformer (see figure 8).
- Insert the other end of the wire, with the connector, into the back of the control box (see figure 8).
- Plug the transformer into a 110 VAC 60 Hz or 230 VAC 50 Hz outlet.

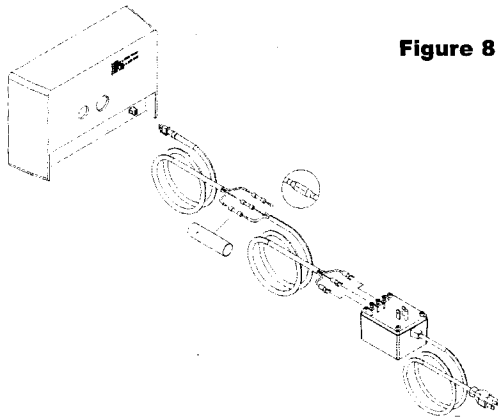

Figure 8

**! Important Note: Not Applicable for TC-CAB Models.**

**! Important Note for TC-CAB Models: The overflow elbow is located on the back of the brine tank (not shown).**

**! Important Note: The brine overflow line must not be higher than the overflow elbow on the brink tank. (This is a gravity overflow.)**

**! Helpful Tip: If the wire is too short, use the supplied connectors and shrink tubing in the warranty pack to lengthen the wire.**

**! Helpful Tip: Squeeze the connector to release it from the box.**

**! Helpful Tip: Check the transformer label for the correct voltage requirement.**

- Insert the safety float into the brine well. The top of the safety float should be about 5 inches from the overflow elbow (see figure 6).

## System Start Up

### 1. Turn on the Water and Check for Leaks

- Close all faucets and turn the water back on at the water meter or pressure tank.
- Check for leaks. If a leak is present, drain the plumbing again before soldering.

### 2. Flush the Remaining Debris from the System

- Open the cold water faucet on your bathtub.
- Allow the system to flush the remaining dirt and debris into the bathtub, until the water runs clear.
- Open all remaining faucets and allow the plumbing to release any trapped air in the system.
- Close all of the faucets.

**Helpful Tip:** This procedure will prevent dirt and debris from entering the valve.

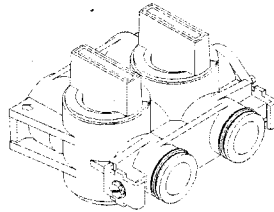

Figure 9

### 3. Open the Bypass Valve

- Move the bypass valve handles to the service position. The valve handles should be parallel to the pipes (see figure 9).
- Open the bathtub faucet again and allow the system to fill with water for approximately 5 minutes. After 5 minutes, test for soft water.

**Helpful Tip:** It is common for new systems to have some color in the water. The color should disappear after you completely flush the system.

### 4. Flush the Hot Water Heater

- Run hot water in the bathtub until the water tests soft.

### 5. Add Salt and Program the Computer

- Please refer to the "Customer Settings" on pages 13-14.

**Important Note:** Do not pour undiluted bleach into the water conditioner.

### 6. Sanitize the Conditioner

- Mix a 3/4 cup of common (unscented) 5.25% household bleach with 1 quart of water. Pour this solution into the brine well.
- Initiate a manual regeneration. The solution will be drawn into the conditioner during the regeneration process.
- After the system has completed a manual regeneration, the conditioner will be sanitized and ready for use.

# Customer Settings

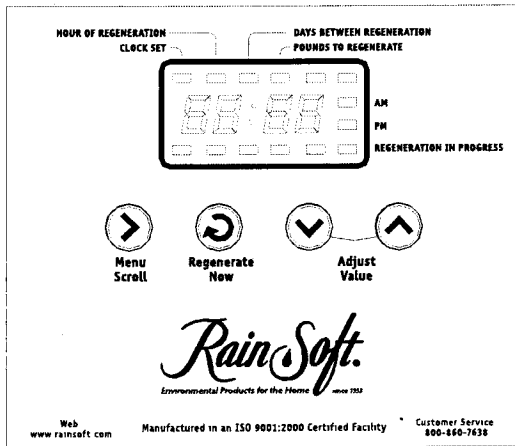

The Customer Settings mode allows access to a variety of programming options:

## Setting the time of day

From the home screen press the **Menu Scroll** button. The clock set icon will begin to flash, use the **up** or **down** arrows to adjust the time of day. Press the **Menu Scroll** button four times to exit

## Setting the regeneration time

From the home screen press the **Menu Scroll** button two times. The hour of regeneration icon will begin to flash, use the **up** or **down** arrows to adjust the regeneration time. Press the **Menu Scroll** button three times to exit

## Setting the days between regeneration

From the home screen press the **Menu Scroll** button three times. The days between regeneration icon will begin to flash, use the **up** or **down** arrows to adjust the days between regeneration. Press the **Menu Scroll** button two times to exit

## Setting pounds of salt

From the home screen press the **Menu Scroll** button four times. The pounds to regenerate icon will begin to flash, use the **up** or **down** arrows to adjust the pounds of salt. Press the **Menu Scroll** button one time to exit

## Manual regeneration

To manually regenerate the system press the **Regenerate Now** button. The control will count down from 10 seconds. To cancel the regeneration press the **Menu Scroll** button before the countdown is complete. Once the regeneration has started you may manually advance to each cycle by pressing and holding the **Menu Scroll** button for 5 seconds.

**! Important Note: When you exit the Customer Settings, the computer will automatically save any changes that have occurred.**

*Example: In this example, we will use the medium capacity (32,300) of a TC 100V unit.  $32,300/6,000$  grains to be softened per day = 5.38 days between regeneration.*

**Note: Always round this number down.** This example unit should regenerate every five days.

## Troubleshooting Guide

Symptoms	Cause	Solution
1. The system fails to regenerate automatically	1. The power supply is plugged into intermittent or dead power source.	1. Connect to a constant power source. 2. Call your RainSoft Dealer for service.
2. The system regenerates at the wrong time	1. The computer is not set properly.	1. Reset the time of day/hour of regeneration.
3. Poor water quality	1. The raw water has changed. 2. Close the bypass valve. 3. The power supply is disconnected.	1. Call your RainSoft Dealer for a new water analysis. 2. Close the bypass valve. 3. Plug in the power supply.
4. Loss of water pressure	1. Low pressure to the unit.	1. Bypass the system. If the problem still exists after bypass, it is not related to a RainSoft product. (Check your water distribution system.) If the problem is resolved after bypass, call your RainSoft Dealer for service.
5. Excessive water in the brine tank and/or salty water	1. The drain line is plugged/restricted. 2. The brine valve is dirty 3. Low inlet pressure. 4. The injector is plugged.	1. Check the water flow to the drain. Check for crimps in the drain line. Call your RainSoft Dealer for service. 2. Call your RainSoft Dealer for service. 3. Call your RainSoft Dealer for assistance. 4. Call your RainSoft Dealer for service.
6. The system fails to use salt	1. The drain line is plugged/restricted. 2. The injector is plugged. 3. Low inlet pressure. 4. No water in the brine tank.	1. Check the water flow to the drain. Check for crimps in the drain line. Call your RainSoft Dealer for service. 2. Call your RainSoft Dealer for service. 3. Call your RainSoft Dealer to increase the inlet pressure. It must be a minimum of 20 psi. 4. Call your RainSoft Dealer for service.
7. Constant flow to the drain	1. Foreign material in the valve. 2. Excessive water pressure.	1. Call your RainSoft Dealer to clean the valve. 2. Install a pressure regulator.

**If the troubleshooting guide did not resolve the symptom, please contact your local RainSoft Dealer for service. If you cannot locate your local RainSoft Dealer, please contact RainSoft Customer Service at 1-800-860-7638 or logon to [www.rainsoft.com](http://www.rainsoft.com) for the name and location of your nearest authorized Dealer.**

# *Limited Lifetime Warranty*

*For as long as you own the equipment*

RainSoft Division of Aquion Water Treatment Products, believing its

## **WATER TREATMENT SYSTEM**

to be of exceptional quality, hereby warrants said equipment to its first purchaser at retail as follows:

**THE TREATMENT TANK, VALVE AND SALT CONTAINER ARE WARRANTED AGAINST DEFECTS IN MANUFACTURE FOR THE LIFETIME OF THE FIRST PURCHASER AT RETAIL.**

**THE ELECTRICAL PARTS ARE WARRANTED AGAINST DEFECTS IN MANUFACTURE FOR FIVE YEARS AND PRO-RATA WARRANTED FOR AN ADDITIONAL FIVE YEARS.**

### **RESINS:**

**ION-X 34 IS WARRANTED AGAINST DEFECTS IN MANUFACTURE FOR TEN YEARS.**

**ION-X 100 IS WARRANTED AGAINST DEFECTS IN MANUFACTURE FOR THE LIFETIME OF THE FIRST PURCHASER AT RETAIL.**

**ION-X 2000 IS WARRANTED AGAINST DEFECTS IN MANUFACTURE FOR THE LIFETIME OF THE FIRST PURCHASER AT RETAIL.**

This warranty begins at the time the equipment is first connected for use, and is contingent upon the return of a signed owner's registration card.

This warranty does not require replacement of the entire unit. If the equipment does not perform properly, you should request service from the dealer that sold you the equipment. If you are not satisfied, you should notify our Customer Service Manager. If we are not able to arrange local servicing, you should send the defective part(s) (or, if you prefer, send the entire unit,) directly to the manufacturer, freight prepaid, with proof of purchase and a copy of this warranty. The defective part(s) (or entire unit) will either be repaired or new RainSoft part(s) furnished, for a nominal charge to cover labor, handling, packing and the increase, if any, in the retail price of the part(s) since the date of purchase. Genuine RainSoft parts must be used. Failure to use genuine RainSoft parts will void the warranty and certifications.

This warranty does not include labor charges, and does not cover installation, transportation, or any other claims or torts. Some states do not allow the exclusion or limitation of incidental or consequential damages, so parts of the above limitation or exclusion may not apply to you.

This warranty gives you specific legal rights, and you may also have other rights which vary from state to state. You also have implied warranty rights. In the event of a problem with warranty service or performance, you may be able to go to a small claims court, a State court, or a Federal District Court.

This warranty is void if equipment is not installed and operated according to instructions. It does not apply to damage caused by abuse, accident, neglect, freezing, fire, or other abnormal conditions beyond the company's control. This warranty is void on any part from which the manufacturing date has been removed or made illegible.

Benefits will be provided by various types of RainSoft equipment when installed and operated according to the manufacturer's recommendations. Operational, maintenance and replacement requirements are essential for the product to perform as advertised. All claims are based on the best available information at the time of printing. Manufacturer makes no representations as to the suitability of this equipment for a particular application. Buyer relies entirely on the dealer's recommendations in the purchase of this equipment.

Independent RainSoft dealers may include, together with your RainSoft product, a product or component that is not manufactured by RainSoft or their parent company, AWTP, LLC. Any non-RainSoft product may be covered by the manufacturer of that product, and is not covered by the RainSoft warranty. AWTP, LLC does not warrant that your RainSoft product and the non-RainSoft product will perform properly when used together, and assumes no liability therefore.

RainSoft Division of Aquion Water Treatment Products  
2080 East Lunt Avenue  
Elk Grove Village, Illinois 60007 USA